

# KVANT 231

---

OPERATING MANUAL



**AUTHOR**  
ALARM

## Dear car owner!

Please notice that the AUTHOR Alarm anti-theft devices are not intended for self-installation.

We strongly recommend installing and configuring the purchased equipment only in certified installation centers. Devices installed by non-certified installers are not subjected to warranty and service!

The manufacturer is not responsible for any damage caused by incorrect use of the device, not abiding the safety rules and the requirements described in this manual.



*This operating manual contains the secret authorization code intended for an emergency unblocking of the engine. Save this manual after installing the system.*



*Do not leave this operating manual with the secret code in the car! Otherwise, the protective functions of the system will be disabled.*

Emergency code

Bluetooth pairing code

## TABLE OF CONTENTS

General information .....	4
Advantages of the system .....	4
<b>OPERATION PRINCIPLE .....</b>	<b>5</b>
Engine blocking .....	5
Alarm deactivation/activation .....	5
Authorization by key fobs or smartphones .....	6
Authorization by the PIN-code .....	7
Two-step authorization mode .....	7
Authorization in an emergency .....	8
The service/valet mode .....	9
Hood lock activator control .....	10
<b>SYSTEM SETTINGS .....</b>	<b>11</b>
Motion sensor sensitivity adjustment .....	11
Two-step authorization mode settings .....	12
Changing of the PIN-code .....	15
Resetting to the factory settings .....	16
<b>KEY FOBS/SMARTPHONES DELETING/ATTACHING ...</b>	<b>17</b>
Key fobs deleting .....	17
Key fobs attaching .....	18
Attaching of the smartphone as key fob .....	20
Attaching of the smartphone (the second way) .....	23
Deleting of the smartphone .....	27
<b>REFERENCE .....</b>	<b>29</b>
The KVANT Immobilizer options .....	29
The key fob diode indication signals .....	31
Wiring diagram .....	32

## **General information**

The KVANT 231 immobilizer is aimed to provide active protection of the car by means of blocking of electrical circuits critical for the engine work. Its special feature is the technology of blocking of the engine with the built-in normally closed relay. The security system can be deactivated using the key fob or the smartphone with the application Author ID installed.

The KVANT does not show its presence in the car until the engine blocking is activated. Moreover, due to the compact size of the device, it may be installed almost everywhere in the car.

The KVANT is the new smart opportunity to protect your car!

## **Advantages of the system**

- Small size of the device allows it to be installed in a secluded place in the cabin or in the under hood space of the car.
- The device does not show itself until the engine blocking is activated.
- The security will be deactivated by the signal of the key fob or the smartphone with the application installed.
- Engine blocking works in the following cases: the car starts moving, the ignition is ON, the gear has been shifted.
- The hood locks shut when the security system is activated.
- The service/valet mode.

## OPERATION PRINCIPLE

### Engine blocking

The KVANT immobilizer prevents the car from being stolen by stopping of the running engine or by prohibition to start the engine. Engine blocking works in the following cases:

- the car starts moving (the accelerometer detects the car motion)
- the ignition is ON (this option is turned-off by default)
- the gear has been shifted (this option is turned-off by default)

### Alarm deactivation/activation

Before driving, the security system should be disarmed by the key fob or the smartphone with the Author ID application installed on it. Successful security system deactivation will be confirmed by two indication signals and driving may be started. In the case authentication process has not been undergone (the key fob or the smartphone attached to the system is absent or unrecognized), the engine will be blocked at the attempt of driving.

The security system will be automatically activated in 10 seconds after the ignition is OFF. Three short indication signals will confirm that the security has been activated and the KVANT immobilizer will automatically close the electromechanical hood locks.

The device monitors the hood status (open/closed) if the corresponding option is enabled and the hood end switch is connected. The hood locks shut within 10 seconds after the hood has been closed. Opening of the hood locks happens after disarming of the system by use of the key fob or the smartphone attached as key fob.

### **Authorization by key fobs or smartphones**



*Do not leave the key fobs the smartphone in the car when parked! Otherwise, the protective functions of the system will be disabled.*

Having the key fob or the smartphone attached as key fob is enough for successfully undergoing of the authentication process. Two smartphones and two key fobs might be simultaneously attached to the same KVANT immobilizer (at least one of the attached devices should be present to sign in).

- Turn on the ignition.
- Successful authentication will be confirmed by two indication signals (light or sound).
- Driving might be begun.

In the case the key fob or the smartphone has not been recognized, no signals will be provided and the engine will be blocked at the attempt of driving.

## Authorization by the PIN-code



*Initial setting of the PIN-code is implemented when turning on the two-step authentication mode (see page 12). In order to disarm the system only by use of the PIN-code (without key fobs or smartphones), the two-step authentication mode should be turned off (see page 14).*

Sit at the steering wheel, turn on the ignition or start the engine (in the case it is required) and enter the valid PIN-code using the service/valet button of the car.

Entering of the PIN-code is recommended right before driving. The time gap between the service/valet button pushes should not exceed two seconds (there is no difference between «long» and «short» pushes).

Entering of the correct PIN-code will be confirmed by two indication signals (light or sound) and driving may be started.

In the case the PIN-code has been entered incorrectly, no signals will be provided and the engine will be blocked at the attempt of driving. The second attempt to enter the PIN-code is available immediately after the failed one.

## Two-step authorization (authentication) mode

Two-step authorization (authentication) in the KVANT system is used for providing maximal safety and protection to the car. When this mode is used, the engine may be started only when both of the conditions listed below have been abided:

- The key fob/the smartphone is within the coverage of the device
- The PIN-code has been entered



 *The PIN-code should be entered only in the case the key fob or the smartphone is present within the coverage of the device. If the PIN-code had been entered before the key fob or the smartphone was recognized by KVANT the authorization (authentication) would not be successful.*

Read more about the two-step authorization (authentication) mode settings on page 12.

## **Authorization in an emergency**

In the case the key fob or the smartphone has been lost or forgotten the emergency authorization (authentication) procedure can be undergone to start the engine.

The emergency code is indicated on the first page of this operating manual and consists of three digits.

In order to enter the emergency code, turn on and off the ignition the number of times corresponding to the first digit of the code. The time gap between the turning on and off of the ignition should not exceed five seconds.

Before entering the next digit at least a 5 seconds pause should be held when the ignition is off (it should not exceed 15 seconds).



Successful authorization (authentication) will be confirmed by the particular number of the indication signals corresponding to the number of the being entered emergency code.

## **The service/valet mode**

The service/valet mode is used for temporary deactivation of the anti-theft system when the car has been provided for service maintenance (without the necessity of telling the service staff about the device).

The service/valet mode might be activated regardless of the ignition state. After signing in by the key fob or the smartphone press the service button 10 times. The button should be pressed within two minutes after entering the PIN-code. The time gap between the pressings should not exceed two seconds. The service/valet mode activation will be confirmed by 10 light or sound signals.

The service/valet mode deactivation is performed by pressing the service button 10 times when the key fob or the smartphone is present in the car. The double indication signal will confirm that the service/valet mode has been deactivated.



*The service/valet mode will not be deactivated when the power has been switched off or at the attempt to switch ON/OFF the ignition. Use the emergency authorization code for the service/valet mode deactivation in the case the key fob or the smartphone is not present within the coverage of the device (see page 8).*

After the service/valet mode deactivation when the engine is being started the key fob the smartphone presence is required.

After leaving the service/valet mode, authorization (authentication) is not required if the ignition has been turned on, turned off for less than 10 seconds and turned on again (the module is working).

### **Hood lock activator control**

When the hood lock activator is connected the hood lock shuts in 10 seconds after alarm has been activated. The hood lock will be opened when security is disarmed. In the service/valet mode the hood lock is always open. If the yellow-green wire (the end switch) is connected, the lock will not shut when the hood is opened, including the cases when alarm is on. When the hood is closed in security mode, the lock shuts within 10 seconds after the hood has been closed.

## SYSTEM SETTINGS

### Motion sensor sensitivity adjustment

The motion sensor of the immobilizer provides five sensitivity levels (sensitivity increases from 1 to 5, by default level 5 is activated). To change the sensitivity level, follow these instructions:

1. Switch the ignition ON without starting the engine.
2. Enter the current PIN-code to authorize. There will be two indication signals.
3. Enter the immobilizer setup menu (the setup menu is available within two minutes after the PIN-code entering). For this purpose press the service/valet button and hold it pressed during 10 seconds. The LED or buzzer will start providing indication signals once in a second.
4. Press the service/valet button twice to enter the sensitivity control sub-menu. The indication LED or buzzer will provide a number of signals, which corresponds to the value of the current sensitivity level (from 1 to 5). After that the immobilizer will start providing series of double indication signals.
5. Set new sensitivity level by pressing the button the required number of times from 1 to 5. The value «1» corresponds to the switched off sensor, the value of «2» – to the lowest sensitivity level (response only to a strong speedup), the value of «5» – to the highest sensitivity level (response to a slight acceleration). Each button press will be confirmed by a single indication signal of the LED or the buzzer. The new saved value of sensitivity level will be confirmed in

three seconds after the end of the setting procedure with the corresponding number of indication signals of the LED or the buzzer (from 1 to 5). If the saving has not been successful, the LED or the buzzer will provide the single indication signal with duration of two seconds. Switch OFF the ignition and repeat the steps 1-4.

6. Switch OFF the ignition.

### Two-step authorization (authentication) mode settings

In the two-step authorization (authentication) mode the engine might be started only in the case both of the conditions have been abided:

- The key fob or the smartphone should be present within the coverage of the device
- The PIN-code is entered with the service button of the car



This mode is turned off by default. In order to activate the two-step authorization (authentication) mode:

1. Switch ON the ignition without starting the engine.
2. Sign in by the key fob or the smartphone. Two indication signals will be provided.
3. Enter the immobilizer setup menu. For this purpose press the service/valet button and hold it pressed for 10 seconds. The LED or the buzzer will start providing indication signals once in a second. Release the service/valet button.

4. To choose the sub menu №5 press the service/valet button 5 times. The LED or the buzzer will confirm successful undergoing of the procedure with 5 signals of indication.
5. To choose the two-step authorization (authentication) setup menu press the service/valet button four times. The LED or the buzzer will confirm successful undergoing of the procedure with one indication signal. It indicates that the two-step authorization (authentication) mode is switched OFF.
6. To activate the two-step authorization (authentication) mode press the service/valet button two times. The LED or the buzzer will confirm successful undergoing of the procedure with two indication signals.
7. Assign the PIN-code combination to the service/valet button. The PIN-code can consist of 3 to 10 pushes. The time gap between the pushes should not exceed two seconds. There is no difference between «long» and «short» pushes of the button. When the PIN-code is entered the LED or the buzzer will confirm successful undergoing of the procedure with two indication signals.
8. Enter the PIN-code once again. If the PIN-code has matched with the previously entered one - two indication signals will be provided and the PIN-code will be successfully saved.
9. Switch OFF the ignition.



*Two-step authorization (authentication) mode is automatically deactivated when deleting all the key fobs and smartphones from the memory of the system.*

If the two-step authorization (authentication) mode should be deactivated:

1. Switch ON the ignition without starting the engine.
2. Sign in by the key fob or the smartphone and enter the valid PIN-code. Two signals of indication will be provided.
3. Enter the immobilizer setup menu. For this purpose press the service/valet button and hold it pressed during 10 seconds. The LED or the buzzer will start providing indication signals once in a second. Release the service/valet button.
4. In order to choose the sub menu №5 press the service/valet button five times. The LED or the buzzer indication will confirm successful undergoing of the procedure with five signals.
5. In order to choose the two-step authorization (authentication) setup menu press the service/valet button four times. The LED or the buzzer indication will confirm successful undergoing of the procedure with two signals. It indicates that the two-step authorization (authentication) mode is switched ON.
6. To deactivate the two-step authorization (authentication) mode, press the service/valet button once. The LED or the buzzer will confirm successful undergoing of the procedure with one indication signal.
7. Switch OFF the ignition.



*If the two-step authorization (authentication) mode has been deactivated, authorization (authentication) may be undergone only by the PIN-code. The key fob or the smartphone is not required anymore.*

## Changing of the PIN-code

The PIN-code may be changed at any moment. For example for security reasons: if the PIN-code has been pried by someone. The PIN-code was set for the first time when the two-step authorization (authentication) mode was turned on. Either the two-step authorization (authentication) mode may be activated once again and through this procedure, the current PIN-code may be changed (see page 12-13) or the PIN-code change mode may be activated.

1. Switch ON the ignition without starting the engine.
2. Sign in by the PIN-code. In the case the two-step authorization (authentication) is used, the key for or the smartphone should be present within the coverage of the device. Two indication signals will be provided by the device.
3. Enter the PIN-code once again within two minutes. The device will proceed to the PIN-code change mode and the indication signals will be provided once every three seconds.
4. Assign the PIN-code combination to the service/valet button. PIN-code may consist of 3 to 10 pushes. The time gap between the pushes should not exceed two seconds. There is no difference between «long» and «short» pushes of the button. When the PIN-code is entered the LED or the buzzer will confirm successful undergoing of the procedure with two indication signals.
5. Enter the PIN-code once again. If the PIN-code matches the previously entered one - two indication signals will be provided and the PIN-code will be successfully saved.

6. If there are four indication signals, it means the PIN-codes have not matched and due to this, the PIN-code has not been saved. Switch OFF the ignition for three seconds and repeat the points 1-5.
7. Switch OFF the ignition.



*Memorize the PIN-code or write it down after it has been changed. Do not leave the information about the new PIN-code and this manual inside the car!*

## **Resetting to the factory settings**

To reset the KVANT to the factory settings follow the next steps:

1. Switch ON the ignition without starting the engine.
2. Sign in by the key fob or the smartphone. Two indication signals will be provided.
3. Enter the immobilizer setup menu. For this purpose press the service/valet button and hold it pressed for 10 seconds. The LED or the buzzer will start providing indication signals once in a second.
4. To reset the device to the factory settings press the service/valet button nine times. The indication signal of the LED or the buzzer will be provided nine times. Press the service/valet button nine times to confirm resetting. The LED or the buzzer will confirm resetting by the indication signal repeated nine times. If resetting has not been performed, the LED or the buzzer will start providing single indication signals two seconds long each. To reset the settings, switch OFF the ignition and repeat steps number 1-3.
5. Switch OFF the ignition.



## KEY FOBs/SMARTPHONES DELETING/ATTACHING

### Key fobs deleting

If the key fob or the smartphone has been lost, it should be deleted out of the device memory in order to prevent the car from being stolen.

 *During this procedure all the saved in the memory key fobs and the smartphones will be erased!*

To delete the key fobs and the smartphones from the system memory, do the following:

1. Switch ON the ignition without starting the engine.
2. Sign in by the key fob/smartphone or enter the PIN-code. Two indication signals will be provided.
3. Enter the immobilizer setup menu. For this purpose press the service/valet button and hold it pressed for 10 seconds. The LED or the buzzer will start providing indication signals once in a second.
4. To choose the sub menu №5 press the service/valet button five times. The LED or the buzzer indication will confirm the action with five signals.
5. To delete the key fobs from the device memory press the service/valet button eight times. The LED or the buzzer indication will confirm successful undergoing of the procedure with eight signals.
6. To confirm the key fobs deleting press the service/valet button eight times again. The LED or the buzzer indication will confirm successful undergoing of the procedure with eight signals. All the key fobs and the smartphones will be deleted from the device memory. If deleting has not been successful, the LED or the buzzer will provide the single indication

signal two seconds long. Switch OFF the ignition and repeat steps number 1-6.

7. Switch OFF the ignition.

## Key fobs attaching

### *Automatic connection*



*This method of connection works only for the new key fobs bought from the manufacturer and never connected before to any immobilizer. For the key fobs, those were once connected and then disconnected use the manual connection procedure (see page 19).*

1. Make sure the key fob can be used for connection with the device:
  - insert the battery in the key fob;
  - ensure the LED is flashing with green.
2. Switch on the key fob connection mode:
  - Switch on the ignition without starting the engine.
  - Sign in by the key fob/smartphone or enter the PIN-code. Two indication signals will be provided.
  - Enter the immobilizer setup menu. For this purpose press the service/valet button and hold it pressed for 10 seconds. The LED or the buzzer will start providing indication signals once in a second.
  - To choose sub menu №5 press the service/valet button five times. The LED or the buzzer indication will confirm successful undergoing of the procedure with five signals.
  - To connect the new key fobs press the service/

valet button three times. The LED or the buzzer indication will confirm successful undergoing of the procedure with three signals.



*The key fobs or the smartphone should be kept as close as possible to the device. The coverage zone is limited (recommended distance up to one meter).*

3. Insert the battery into the new key fob. The LED on key fob will start flashing continuously with green. After successful connection the LED will blink once with red light. If connection has not been successful, the green light blinking will stop in 30 seconds after inserting the battery.
4. Switch OFF the ignition.
5. Reset the KVANT system by disconnecting and connecting again to the +12V power supply (disconnect the car battery terminals). Check out workability of the key fob after having been connected to the device.

### *Manual connection*



*This method works for the key fobs which have already been connected and then disconnected from some immobilizer produced by Author-Alarm.*



*The key fobs with indication M52L on the print should only be used. Do not use the older versions of the key fobs with indication M24 on the print.*

1. Switch on the key fobs connection mode as indicated in passage 2 on page 18.
2. Close the contacts on the key fob (with a piece of aluminum foil or a piece some other material that

can conduct electric current) as shown on the drawing and insert the battery element. The LED on the key fob will start flashing continuously with green light. After successful connection the LED will blink once with red light. If the connection has not succeeded, the green blinking will stop in 30 seconds after inserting the battery.



3. Switch OFF the ignition.
4. Reset the KVANT system by disconnecting and connecting again to the +12V power supply (disconnect the car battery terminals). Check out workability of the key fob after having been connected to the device.

### **Attaching of the smartphone as key fob**

The KVANT immobilizer supports connection of two smartphones that can be used as a key fob for quick authorization.

In order to do that the car owner must have the smartphone connected to the system with the application Author ID working on the background (even when the smartphone screen is off).

This function is available for most of the smartphones with different operation systems:

- iOS 8.0 or above
- Android 5.0 or above (Bluetooth 4.0+ LE)

For authorization (authentication) in the KVANT system by the smartphone, download and install the Author ID application:

<https://itunes.apple.com/ru/app/author-id/id1144594689?mt=8>

<https://play.google.com/store/apps/details?id=com.dma.author.authorid>



 *The maximal number of the smartphones that might be used as key fobs is two. Only one phone may be attached to the device as key fob over one attaching session.*

Undergo the next steps to attach the phone to the device:

1. Switch on the Bluetooth on the smartphone.
2. Start the Author ID application.

 *«Bluetooth Peripheral mode not supported». If you have this message in Author ID application in your smartphone, use the additional mode in the KVANT system (see page 23).*

3. Switch on the ignition without starting the engine.
4. Sign in the system by the key fob/smartphone or enter the PIN-code. Two indication signals will be provided.

5. Activate the smartphone pairing mode:

- Switch ON the ignition without starting the engine.
- Sign in by the key fob or the smartphone (or enter the PIN-code if the two-step authorization (authentication) is used). Two indication signals will be provided.
- Enter the immobilizer setup menu. For this purpose press the service/valet button and hold it pressed for 10 seconds. The LED or the buzzer will start providing indication signals once in a second.
- Choose point №5 in the menu by pressing the service/valet button five times. The indication signal of LED or the buzzer will be provided five times.
- To activate the smartphone pairing mode press the service/valet button twice. The indication signal of LED or the buzzer will be provided twice.

6. Press the «+»-button to add the new device.

 *KVANT 231 coverage zone at the moment of device recording is limited. In order to successfully tie a smartphone to the device, keep it as close to the device as possible (recommended distance is up to one meter).*



7. In the pop-up window enter the Bluetooth pairing code indicated on the first page of this manual. After having this done, the smartphone will be connected to the KVANT system.
8. Press the «Key» button in the center of the screen in order to activate the key fob mode (the button lighting will change from grey to orange color).
9. Switch OFF the ignition. Now smartphone works as a key fob. The connection to the KVANT system is realized through the encrypted channel.



*The smartphone works as a key fob only when the Bluetooth is on and the Author ID application is launched.*

The smartphone used as a key fob can reach the car from up to 10 meters distance (depends on the particular place in the car where the KVANT has been installed).

### **Attaching of the smartphone (the second way)**

If the smartphone does not support the Bluetooth Peripheral mode, the device should be transferred in mode number two in order for the phone to work as a key fob.



*Mode number two is available only for KVANT 231 with the radio version 7.0 or above (see the information on the box). Some of the phone models are incompatible with the KVANT 231 immobilizer.*

### *Mode number two (turning on):*

1. Turn on the ignition without starting the engine.
2. Sign in using the key fob/smartphone or by entering the PIN-code. Two indication signals will be provided.
3. Enter the immobilizer setup menu. In order to do it, press the service button and keep it pressed for 10 seconds. The indication seconds will be being repeated once in a second. Release the service button.
4. Enter the options submenu. In order to it, press the service button five times. Five light or buzzer signals will be provided.
5. Change the mode two setup option. In order to do it, press the service button six times. A signal indication signal will be provided that will mean that mode number two is currently disabled.
6. In order to turn on mode number two, press the service/valet button twice. The system will provide a double indication signal as the confirmation of mode two activation.
7. Turn off the ignition.

### *Smartphone attaching in mode two:*



*Ensure that the smartphone that is meant to be paired with the device has not been paired with the other systems of the car (stereo system, hands free calling system and so on). All the active key fobs and smartphones should be out of the coverage (retrieve the power supplying elements out of the key fobs, turn on the Bluetooth on the smartphones earlier attached to the system).*



1. Turn on the ignition without starting the engine.
2. Enter the current PIN-code for signing in (in the two-step authentication method is used, the key fobs/ the smartphone should be within the coverage of the device). The indication signal will be provided twice.
3. Enter the immobilizer setup menu. In order to do it, press the service button and keep it pressed for 10 seconds. The indication signals will be being repeated once in a second. Release the service button.
4. Choose point number five in the setup menu. The indication diode or the buzzer will provide two signals.
5. Choose point number two by pressing the service/ valet button twice. The diode or the buzzer will provide two signals.
6. Turn on the Bluetooth device on the smartphone and search for new devices.



*KVANT 231 coverage zone at the moment of device recording is limited. In order to successfully tie a smartphone to the device, keep it as close to the device as possible (recommended distance is up to one meter).*

7. Choose the KVANT 231 in the list of the available devices.
8. In the pop-up window enter the smartphone pairing code, indicated on the plastic card, included in the device kit. If the window had disappeared before the code was entered, point number two should be repeated.
9. Turn off the ignition and take a 10 second pause.

10. Turn off and on the Bluetooth device on the smartphone.

11. Ensure that the Bluetooth connection with the KVANT 231 has been saved in the phone memory.

Turn on the ignition. Successful smartphone registration in the system will be confirmed by two indication signals. Start the engine and drive; the engine will not be blocked. The smartphone will work as a key fob ever after in mode number two.

 *In order for the smartphone to work as a key fob, the Bluetooth device should be always turned on.*

The smartphone can be identified by the KVANT 231 within 10 meter radius around the car.

In order to delete the smartphone out of the system, the smartphone deleting procedure should be undergone according to the respective paragraph (see page 27).

*Mode number two deactivation:*

1. Turn on the ignition without starting the engine.
2. Sign in using the key fob/ the smartphone or by entering the current PIN-code. Two indication signals will be provided.
3. Enter the immobilizer setup menu. Press the service/ valet button and keep it pressed for ten seconds. The indication signals will be being repeated once in a second. Release the service button.
4. Enter the options submenu. In order to do it, press the service button five times. Five light or sound indication signals will be provided in respond.

5. Choose mode number two setup. In order to do it, press the service/valet button six times. The indication signals will be provided, that will connote that the mode is active at the moment.
6. For mode number two deactivation, press the service/valet button once. The system will provide one indication signal as confirmation.
7. Turn off the ignition.

## Deleting of the smartphone

If attaching of the smartphone to the KVANT system has not been successful or if the smartphone should be untied from the device, the next steps should be undergone.



*In the case the smartphone has been lost delete it from the memory of the KVANT system immediately for security reasons.*

1. Switch ON the ignition without starting the engine.
2. Sign in by the key fob or the smartphone. Two indication signals will be provided.
3. Enter the immobilizer setup menu. For this purpose press the service/valet button and hold it pressed for 10 seconds. The LED or the buzzer will start providing indication signals once in a second.
4. Choose point N°5 in the menu by pressing the service/valet button five times. The indication signal of the LED or the buzzer will be provided five times.
5. To delete all the smartphones, press the service/valet button seven times. The indication signal of the LED or the buzzer will be provided seven times.

6. To confirm the smartphones deleting procedure, press the service button seven times again. The indication signal of the LED or the buzzer will be provided seven times. All the smartphones will be deleted from the KVANT memory.

If the deleting procedure has not been successful, the LED or the buzzer will provide the single indication signal two seconds long. In that case switch OFF the ignition and repeat steps 1-6.

7. Switch OFF the ignition. After having it done, delete the link between the devices in the smartphone: Settings – Bluetooth – Devices – KVANT – Delete connection (cancel pairing, forget device, etc.).



*If the device has been working in mode number two, and the smartphone used for signing in has been lost, the mode should be immediately deactivated. Use the respective paragraph of the manual in order to do this (mode number two deactivation).*

## REFERENCE

### The KVANT Immobilizer options

The value of the particular option set in the system defined by default (ON/OFF) is colored in gray in the table below. The figures in the table show the number of the service/valet button pushes in order to choose the particular option value.

Nº	Option	OFF	ON
2	Accelerometer sensor sensitivity	1	2...5
3	Ignition block	1	2
4	Hood end switch		1
	AT block		2
5	Smartphones attaching		2
	Key fobs attaching		3
	Two-step authorization (authentication)	4 *	
	Smartphone as a key fob	6 *	
	Smartphones deleting		7**
	Key fobs and smartphones deleting		8**
6	The STM firmware change mode		
7	The nRF firmware change mode		7
9	Factory settings		9

\* See «Settings».

\*\* In order to confirm the key fob/smartphone deleting procedure, press the service/valet button seven or eight times respectively.

In order to change the option value, do the next:

1. Switch ON the ignition without starting the engine.

2. Sign in the system by the key fob/smartphone or enter the PIN-code - two indication signals will be provided.
3. Enter the immobilizer setup menu. For this purpose press the service/valet button and hold it pressed for 10 seconds. The LED or the buzzer will start providing indication signals once in a second.
4. To enter the desired sub-menu, press the service/valet button the number of times that corresponds to the option number you need. The LED or the buzzer will provide the number of signals corresponding to the current option value. Afterwards the diode or the buzzer will provide the number of signals that corresponds to the sub-menu number.
5. To choose the desired option state (ON/OFF), press the service button the corresponding number of times (see the information in the table). For example:
  - Press the service/valet button twice to activate «AT block»
  - Press the service/valet button 3 times to activate the «key fob attaching» mode
  - Press the service/valet button 7 times to delete the smartphone

The LED or the buzzer will provide the number of the indication signals corresponding to the number of the chosen value.



*Press the service/valet button 7 or 8 times respectively for key fobs/smartphones deleting confirmation.*

If the deleting has not succeeded, the LED or the buzzer will provide the two seconds long signal. In this case, switch OFF the ignition and repeat steps 1-5.

6. Switch OFF the ignition.

## The key fob diode indication signals

After the battery element installation, the key fob LED can provide the following signals:

Color	LED signal	Description
Green	Single flash	The battery is good
Red	Single flash	The battery is low*
Orange (green+red)	Single flash (five seconds long)	The accelerometer is malfunctioned**
Green	Flashes for 30 seconds	The key fob pairing mode
Red	Flashing for three seconds	Successful pairing

If the key fob has been motionless for more than 10 minutes, it goes into the «sleep»-mode with low power consumption. Leaving of the «sleep»-mode happens automatically when having been moved.

\* Replacing of the battery element with a new one is recommended!

\*\* If the accelerometer is out of order the key fob will not proceed to the «sleep» -mode, however, it still may be used for signing in.

## Wiring diagram

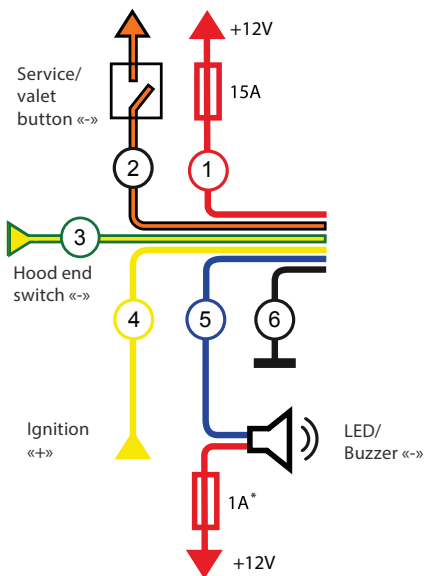

- 1. Red.** +12V power supply connected via 15A fuse.
- 2. Orange-Black.** The service/valet button «-».
- 3. Yellow-Green.** Hood end switch «-» (to the hood lock control module or to the parking lamp (P) on the AT selector to lock the engine if the AT has been shifted).
- 4. Yellow.** Ignition «+».
- 5. Blue.** The LED/ the buzzer «-».
- 6. Black.** Ground (permanent «minus»).

\* The 1 A fuse is not included in the KVANT 231 set.



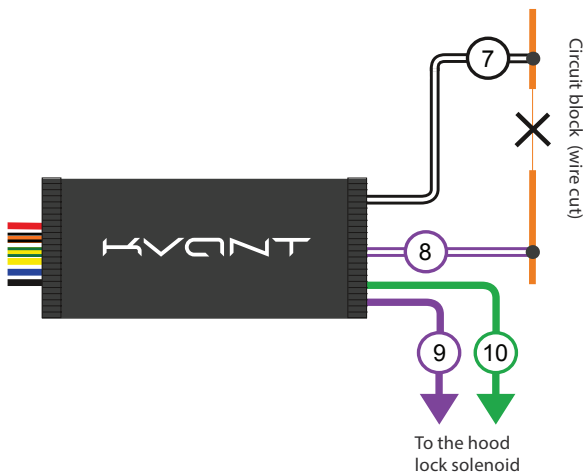

**7. Black-White.** Common wire (COM).

**8. White-Purple.** The Normally Closed contact.

**9. Purple.** to the hood lock solenoid.

**10. Green.** to the hood lock solenoid.

 *To prevent the KVANT 231 module from voltage drop when the LED/Buzzer circuit is closed, it is recommended to install a separate 1A fuse in the LED/Buzzer power supplying wire.*

## Specification

Operating voltage	9-15 V
Working temperature range	from -40 to +85 °C
Consuming current in the protection mode	not more than 10 mA
Commutation current of the relay	not more than 20 A
Current for LED/Buzzer control (blue wire)	not more than 250 mA

## The immobilizer set content

KVANT 231	1 pcs.
Key fobs	2 pcs.
Buzzer	1 pcs.
Button	1 pcs.
15A fuse	1 pcs.
Operating manual	1 pcs.
Box	1 pcs.



Made in Russia  
Manufacturer: LLC «AUTHOR»  
C-RU.AЛ14.B.10098

The developer and the manufacturer retain the right to make technical updates not specified in this operating manual. To learn more visit our web-site:

<http://author-alarm.com>



## Immobilizer location

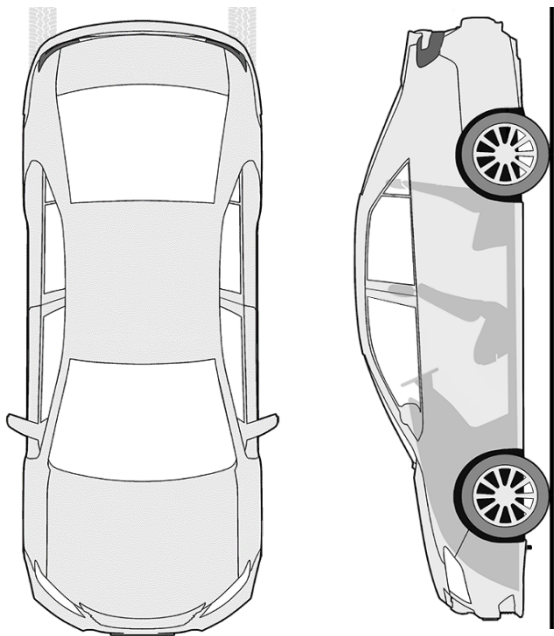

*Do not leave this operating manual inside the car!*

---

---

---

## WARRANTY CERTIFICATE

Warranty time is 12 months from the date of the purchase. During this period technical support and maintenance are guaranteed free of charge. The warranty does not apply to the items with:

- mechanical damage, burnt and char pieces, components, conductive tracks etc.;
- traces of an independent and not professional repair;
- damage caused by natural hazards, fire, social factors;
- damage in the warranty seal, damage or absence of a factory/trade labels.

Only devices with full completeness of set and with the original packing are taken for warranty service.

Absence of packing is regarded as noncompliance with transportation rules. The warranty does not apply to the damage incurred to another equipment operating together with this device.

Item (model) \_\_\_\_\_

Date of sale \_\_\_\_/\_\_\_\_/\_\_\_\_

The contents of the set \_\_\_\_, device operation \_\_\_\_ and absence of mechanic damage \_\_\_\_ are checked.

I am acquainted and agree with the conditions of warranty service:

Buyer \_\_\_\_\_

Seller \_\_\_\_\_ seal









Supported Cars List App.

